

# ROTATING RANGE

## MAIN FEATURES

- 12V or dual voltage (12/24V) options
- 70mph rated on magnetic version
- Current consumption: 4.6A @ 12V, 3.0A @ 24V
- -30°C to +50°C extreme temperature reliability
- Unique maintenance free direct drive mechanism provides low noise operation
- Extra tough polycarbonate lenses



## KEY POINTS

**R65** APPROVED   **R10** APPROVED   1 YEAR WARRANTY   **IP56** INGRESS PROTECTION

## LENS COLOURS

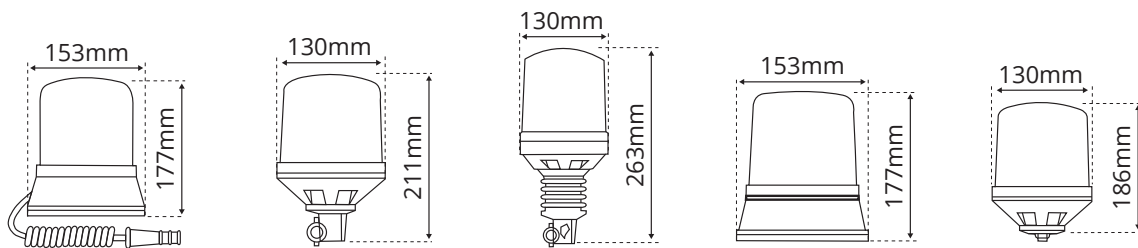

LAP259 (12V)	LAP269 (12V)	LAP271 (12V)	LAP254 (12V)	LAP121 (12V)
LAP260 (12/24V)	LAP270 (12/24V)	LAP272 (12/24V)	LAP255 (12/24V)	LAP122 (12/24V)
Magnetic	DIN	Flexi-DIN	3-Point	Single Point
1.2KG	0.8KG	0.8KG	0.5KG	0.7KG

ECE R65 Approval is appropriate to rotating beacons with either an amber or blue lens fitted. 12/24V units are supplied without bulbs.

# RCB040

## MAIN FEATURES

- Dual voltage (12/24V)
- ECE R65 approved (amber lens only)
- Supplied with 12V and 24V bulbs
- -15°C to +40°C extreme temperature reliability
- Maintenance free worm drive mechanism

## KEY POINTS

**R65** APPROVED   **R10** APPROVED   1 YEAR WARRANTY   **IP56** INGRESS PROTECTION

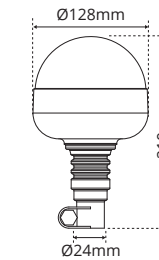

## LENS COLOURS



# RCB040LED

## MAIN FEATURES

- Multi-voltage (10-30V)
- Lightweight (560g)
- 40 LEDs that can operate in 3 selectable flash patterns – rotating, double flash and quad flash
- -15°C to +40°C extreme temperature reliability

## KEY POINTS

**LED**   **R10** APPROVED   1 YEAR WARRANTY   **IP56** INGRESS PROTECTION

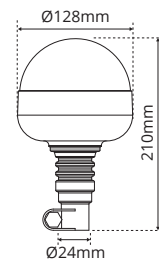

## LENS COLOURS



# LFB LED RANGE

## MAIN FEATURES

- Multi-voltage (10-30V)
- 12 x 3W high-performance LEDs
- R65 approved for amber lens only
- Single, double (default), triple & quad ECE R65 approved flash patterns\*
- 3-point and single point models can be linked for synchronised flash
- Current consumption: 2.0A @ 12V, 1.3A @ 24V
- -30°C to +50°C extreme temperature reliability



## KEY POINTS



## LENS COLOURS

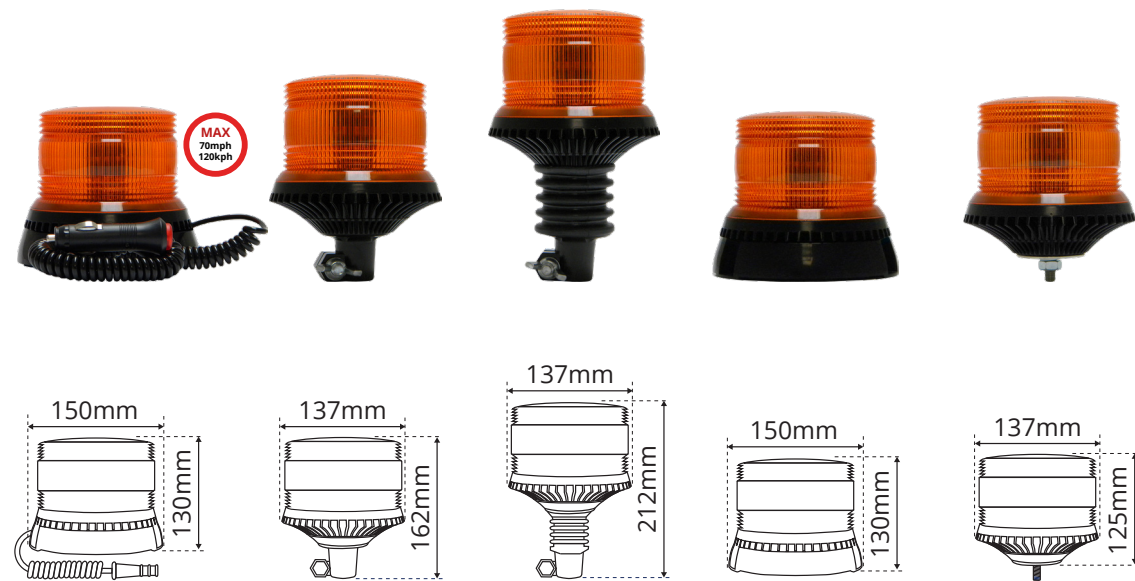

LFB020	LFB030	LFB040	LFB050	LFB060
Magnetic	DIN	Flexi-DIN	3-Point	Single Point
1.2KG	0.7KG	0.9KG	0.7KG	0.7KG

\*Double flash only on DIN and Flexi-DIN models

# LPB LED RANGE

## MAIN FEATURES

- Multi-voltage (10-30V)
- Double flash & rotating patterns meet R65 (amber and clear models only)
- Manufactured with 12 x 3W LEDs
- Current consumption: 1.8A @ 12V, 0.9A @ 24V
- Selectable CAP168 airport flash pattern
- Clear lens/amber flash model (page 12)
- -30°C to +50°C extreme temperature reliability
- Heavy duty aluminium base



## KEY POINTS



## LENS COLOURS



LPB020	LPB040	LPB050	LPB060
Magnetic	Flexi-DIN	3-Point	Single Point
0.7KG	0.8KG	0.5KG	0.5KG



# LPBC LED RANGE

## MAIN FEATURES

- Multi-voltage (10-30V)
- Double flash & rotating patterns meet R65 (amber and clear models only)
- Manufactured with 12 x 3W amber LEDs
- Current consumption: 1.8A @ 12V, 0.9A @ 24V
- Selectable CAP168 airport flash pattern
- Amber lens LPB range available (page 11)
- -30°C to +50°C extreme temperature reliability
- Heavy duty aluminium base



## KEY POINTS



## LENS COLOURS

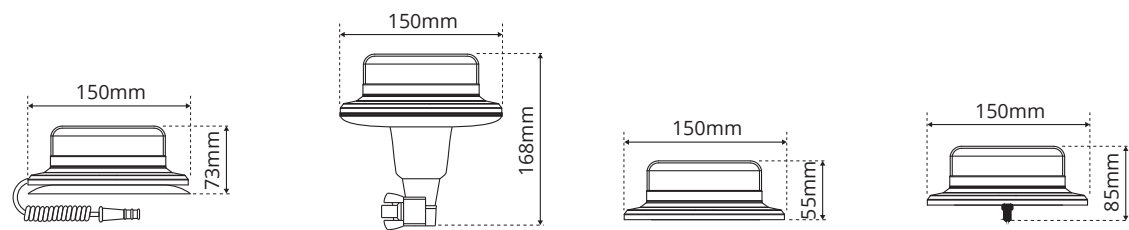

LPB020C	LPB040C	LPB050C	LPB060C
Magnetic	Flexi-DIN	3-Point	Single Point
0.7KG	0.8KG	0.5KG	0.5KG

# ELPB LED RANGE

## MAIN FEATURES

- Multi-voltage (10-30V)
- Manufactured with 12 x 1W LEDs
- Four R65 approved selectable flash patterns (single, double, quad and simulated rotating)
- 70mph/112kmh speed rating for magnetic models (ELPB020)
- Current consumption: 1.0A @ 12V, 0.5A @ 24V
- -30°C to +50°C extreme temperature reliability
- Seat belt kits also available (see page 23)



## KEY POINTS



## LENS COLOURS

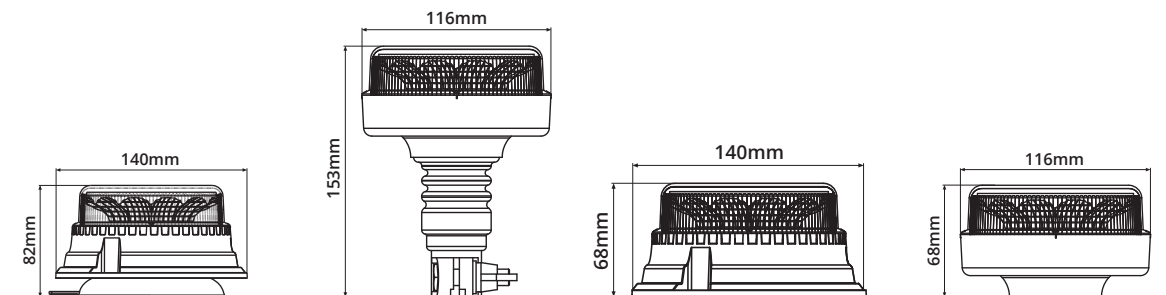

ELPB020	ELPB040	ELPB050	ELPB060
Magnetic	Flexi-DIN	3-Point	Single Point
0.4KG	0.5KG	0.3KG	0.3KG

# LKB LED RANGE

## MAIN FEATURES

- Multi-voltage (10-30V)
- ECE R65 approved
- Manufactured with 8 x 4W amber LEDs
- 70mph rated on magnetic version
- Nominal flash rate: 120 per minute
- Double flash
- Current consumption: 1.2A @ 12V, 0.6A @ 24V
- -30°C to +50°C extreme temperature reliability



## KEY POINTS



## LENS COLOURS

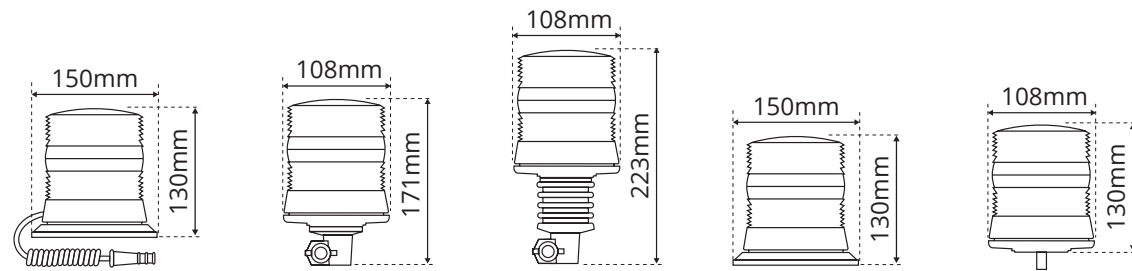

LKB020	LKB030	LKB040	LKB050	LKB060
Magnetic	DIN	Flexi-DIN	3-Point	Single Point
1.1KG	0.8KG	0.8KG	0.5KG	0.7KG

# LKBC LED RANGE

## MAIN FEATURES

- Multi-voltage (10-30V)
- ECE R65 approved
- Manufactured with 8 x 4W amber LEDs
- 70mph rated on magnetic version
- Nominal flash rate: 120 per minute
- Double flash
- Current consumption: 1.2A @ 12V, 0.6A @ 24V
- -30°C to +50°C extreme temperature reliability



## KEY POINTS



## LENS COLOURS

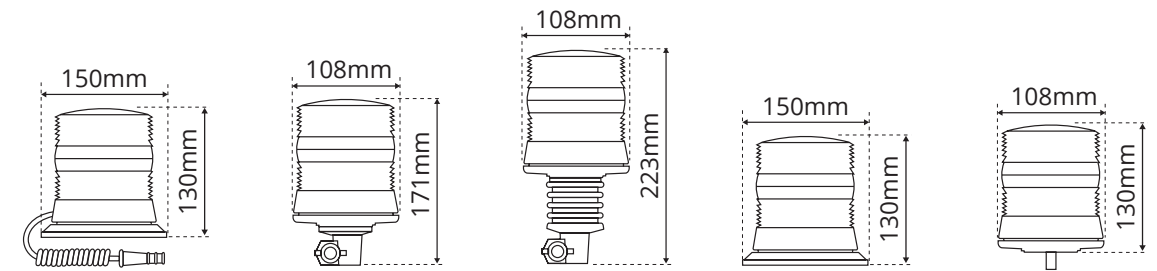

LKB020C	LKB030C	LKB040C	LKB050C	LKB060C
Magnetic	DIN	Flexi-DIN	3-Point	Single Point
1.1KG	0.8KG	0.8KG	0.5KG	0.7KG



# VLKB LED RANGE

## MAIN FEATURES

- Multi-voltage (12-80V)
- Single, double (R65), quad & quick flash patterns
- Internal switch for flash pattern change
- 70mph rated on magnetic version (VLKB020)
- IP67 ingress protected
- Current consumption: 1.3A @ 12V, 0.6A @ 24V
- Tough polycarbonate amber lens



## KEY POINTS



## LENS COLOURS

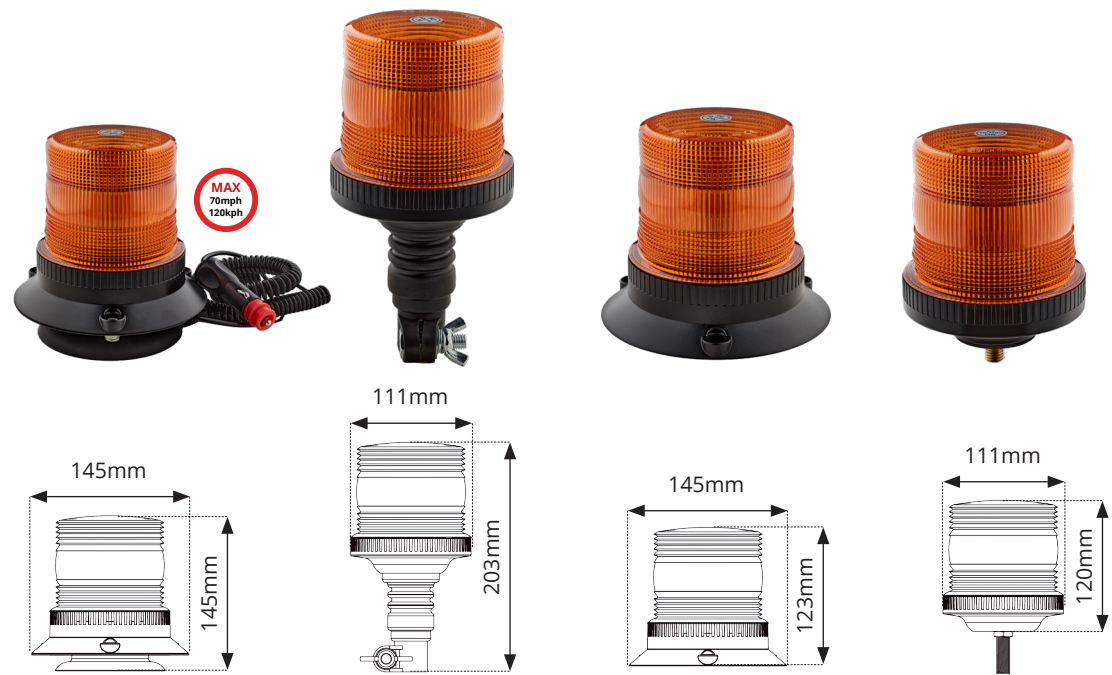

VLKB020	VLKB040	VLKB050	VLKB060
Magnetic	Flexi-DIN	3-Point	Single Point
1.1KG	0.8KG	0.5KG	0.7KG

# VLCB LED RANGE

## MAIN FEATURES

- Multi-voltage (10-110V)
- Quad flash only
- Manufactured with 20 x high power LEDs
- 70mph rated on magnetic version (VLCB020)
- IP67 ingress protected
- Current consumption: 1.0A @ 12V, 0.6A @ 24V
- Blue, green and red lenses
- Seat belt kits also available (see page 23)



## KEY POINTS



## LENS COLOURS



VLCB020	VLCB040	VLCB050	VLCB060
Magnetic	Flexi-DIN	3-Point	Single Point
1.1KG	0.8KG	0.5KG	0.7KG

# LTB LED RANGE

## MAIN FEATURES

- Multi-voltage (10-30V)
- ECE R65 approved (amber lens models)
- Manufactured with 45 x LEDs
- 40mph rated on magnetic version (LTB020)
- 2 selectable flash patterns – double flash (R65 approved) and simulated rotating
- Current consumption: 2A @ 12V, 1A @ 24V
- -30°C to +50°C extreme temperature reliability



## KEY POINTS



## LENS COLOURS

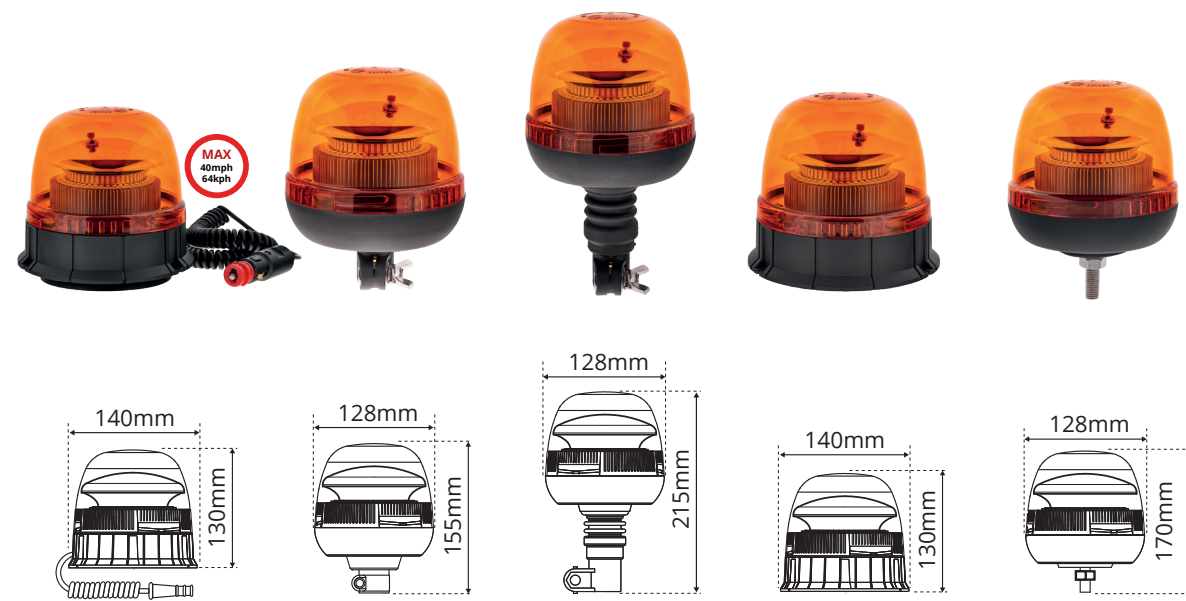

LTB020	LTB030	LTB040	LTB050	LTB060
Magnetic	DIN	Flexi-DIN	3-Point	Single Point
0.8KG	0.7KG	0.8KG	0.7KG	0.7KG

# LMB LED RANGE

## MAIN FEATURES

- Multi-voltage (10-30V)
- Nominal flash rate: 120 per minute (rotating) and 75 per minute (double & quad)
- Manufactured with 40 x LEDs
- Current consumption: 1.2A @ 12V, 0.6A @ 24V
- 3 flash patterns: rotating, double & quad flash
- Fully encapsulated electronics
- Seat belt kits also available (see page 23)



## KEY POINTS



## LENS COLOURS



LMB020	LMB030	LMB040	LMB050	LMB060
Magnetic	DIN	Flexi-DIN	3-Point	Single Point
0.6KG	0.5KG	0.5KG	0.4KG	0.5KG



# LCB LED RANGE

## MAIN FEATURES

- Multi-voltage (10-100V)
- Manufactured with 4 x high powered LEDs
- 70mph rated on magnetic version (LCB020)
- Nominal flash rate: 80 per minute
- Double flash
- Current consumption: 0.6A @ 12V, 0.3A @ 24V
- -30°C to +50°C extreme temperature reliability
- Green beacons also available with seat belt kits (see page 23)



## KEY POINTS



## LENS COLOURS

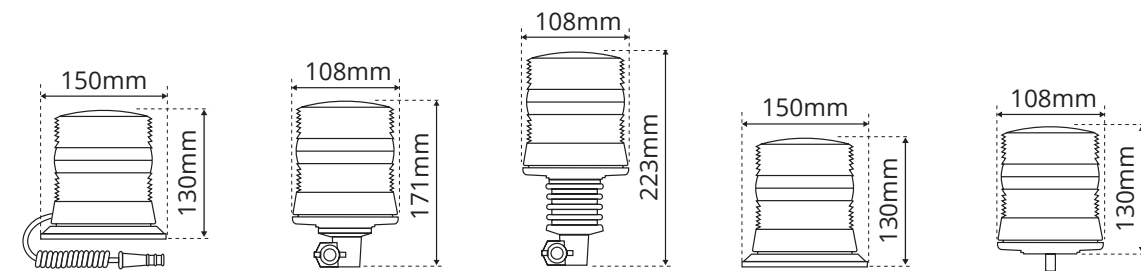

LCB020	LCB030	LCB040	LCB050	LCB060
Magnetic	DIN	Flexi-DIN	3-Point	Single Point
1.1KG	0.8KG	0.8KG	0.5KG	0.7KG

# MLPB COMPACT LED RANGE

## MAIN FEATURES

- Multi-voltage (10-30V)
- EMC (ECE R10) approved
- Three selectable flash patterns (eight-flash, rotating & quad flash)
- Manufactured with 18 x 0.5W LEDs
- Ultra-compact and low-profile design
- Low current consumption: 0.8A @ 12V, 0.4A @ 24V
- 110mm PCD for 3-point fitting models (MLPB050)
- Combine with LAP912 seat belt to create beacon + seat belt kit (see page 23)



## KEY POINTS



## LENS COLOURS

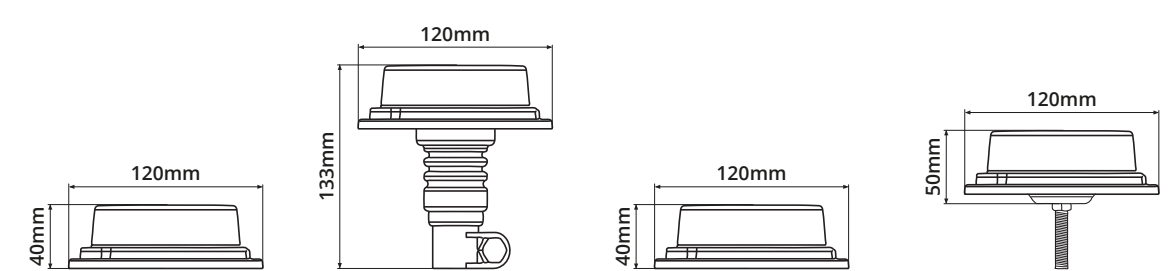

MLPB020	MLPB040	MLPB050	MLPB060
Magnetic	Flexi-DIN	3-Point	Single Point
0.3KG	0.3KG	0.1KG	0.1KG

# LXB LED RANGE

## MAIN FEATURES

- Multi-voltage (10-30V)
- Combining amber & green LEDs into one beacon
- Three selectable flash patterns (single, double & rotating)
- Manufactured with 12 x amber and 12 x green LEDs
- Amber only flash when seat belt is disengaged
- Alternate amber/green flash when seat belt is engaged
- Quick-release mini plug on LXB040AG for ease of removal or replacement



## KEY POINTS



## LENS COLOURS

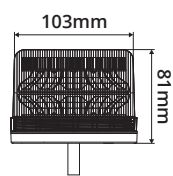
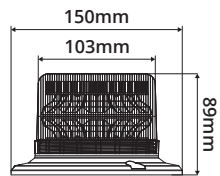
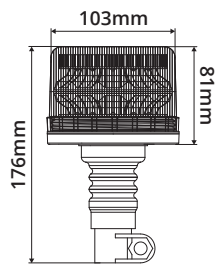

LXB040AG	LXB050AG	LXB060AG
Flexi-DIN	3-Point	Single Point
0.5KG	0.4KG	0.4KG

# LAP912 SEAT BELT

## MAIN FEATURES

- Multi-voltage (10-30V)
- ECE R16 approved
- Seat belt 1.3m in length
- Supplied as LAP912 seat belt & buckle only
- Combine with any ELPB, VLCB, LMB OR MLPB beacon to create seat belt + beacon kit
- Amber, blue, purple & red beacons also available



ELPB Range  
Other Lenses Available ●●●



VLCB Range  
Other Lenses Available ●●●●



Amber, blue, purple & red lenses available



LMB Range  
Other Lenses Available ●●●●



MLPB Range  
Other Lenses Available ●

## LAP912 SEAT BELT + GREEN BEACON KITS

Range	Magnetic	Flexi-DIN	3-Point	Single Point
ELPB	ELPB020G/912	ELPB040G/912	ELPB050G/912	ELPB060G/912
VLCB	VLCB020G/912	VLCB040G/912	VLCB050G/912	VLCB060G/912
LMB	LMB020G/912	LMB040G/912	LMB050G/912	LMB060G/912
MLPB	MLPB020G/912	MLPB040G/912	MLPB050G/912	MLPB060G/912



# LLP & LLT LED RANGE

## MAIN FEATURES

- Multi-voltage (10-130V)
- Two-point fixing
- LLPMV dimensions: 77mm (Ø) x 45mm (H)
- LLTMV dimensions: 77mm (Ø) x 95mm (H)
- Low power consumption (0.1 Amps)
- 4 flash patterns (static, single, double, quad)

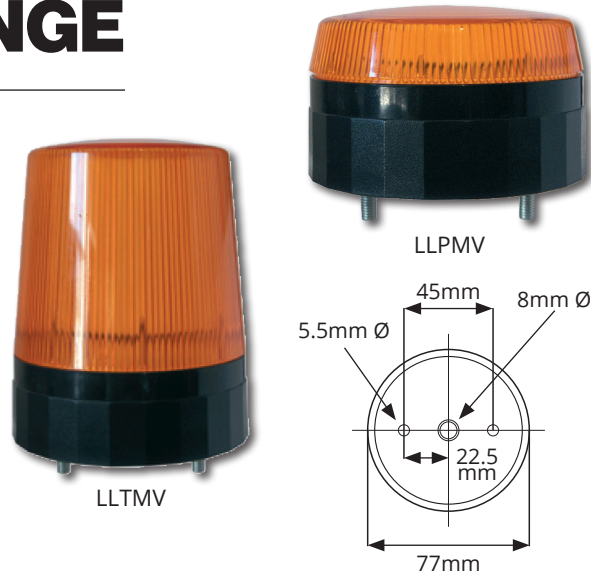

## KEY POINTS



## LENS COLOURS



# VLPMV LED RANGE

## MAIN FEATURES

- Multi-voltage (10-110V)
- Two-point fixing
- Quad flash only
- VLPMV dimensions: 81mm (Ø) x 55mm (H)
- Manufactured with 20 x white LEDs
- Low power consumption (0.1 Amps)



## KEY POINTS



## LENS COLOURS



# XCBMV XENON RANGE

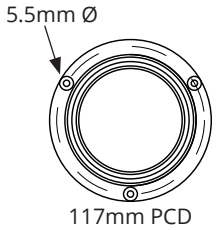

## XCBMV 1611 - MAIN FEATURES

- EMC approved
- Multi-voltage (10-80V)
- -30°C to +50°C extreme temperature reliability
- Nominal flash rate: 75 per minute
- Current consumption: 0.17A @ 12V, 0.15A @ 24V, 0.12A @ 48V, 0.09A @ 80V, 0.07A @ 100V
- Dimensions: 129mm (D) x 90mm (H)



## KEY POINTS



## LENS COLOURS



## XCBMV 2111 - MAIN FEATURES

- EMC approved
- Multi-voltage (10-80V)
- -30 to +50°C extreme temperature reliability
- Nominal flash rate: 75 per minute
- Current consumption: 0.17A @ 12V, 0.15A @ 24V, 0.12A @ 48V, 0.09A @ 80V, 0.07A @ 100V
- Dimensions: 98mm (D) x 132mm (H)



## KEY POINTS



## LENS COLOURS



# STATIC RANGE

Selectable CAP168 Flash Pattern

## MAIN FEATURES

- EMC approved
- 70mph rated on magnetic version
- 12V and 24V models available
- Amber model conforms to CAP168 regulations
- Single flash
- Nominal flash rate: 80 flashes per minute
- Current consumption: 1.0A @ 12V, 0.5A @ 24V



## KEY POINTS

1 YEAR WARRANTY  
IP56 INGRESS PROTECTION

## LENS COLOURS

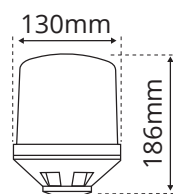
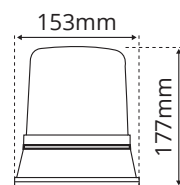
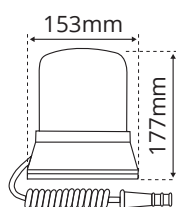

LAP223 (12V)	LAP221 (12V)	LAP225 (12V)
LAP224 (24V)	LAP222 (24V)	LAP226 (24V)
Magnetic	3-Point	Single Point
1.1KG	0.8KG	0.8KG

# RECHARGEABLE RANGE

## LPB020BAT

R65 APPROVED  
R10 APPROVED  
2 YEAR WARRANTY  
IP56 INGRESS PROTECTION

- Manufactured with 12 x 3W LEDs
- Double flash & rotating flash meet R65 approval
- Rechargeable battery with 4 hour discharge time
- Dimensions: 130mm (Ø) x 79mm (height)
- Supplied with in-car and mains power adaptors
- Green and red lenses available on request



## LAP1284AC/BAT

R65 APPROVED  
R10 APPROVED  
2 YEAR WARRANTY  
IP65 INGRESS PROTECTION

- Manufactured with 78 x 0.5W amber LEDs
- Single flash meets R65 approval
- Rechargeable battery with 4-10 hour discharge time
- Green/amber/red battery level warning light
- Dimensions: 305 (L) x 158 (W) x 59mm (H)
- Supplied with in-car and mains power adaptors

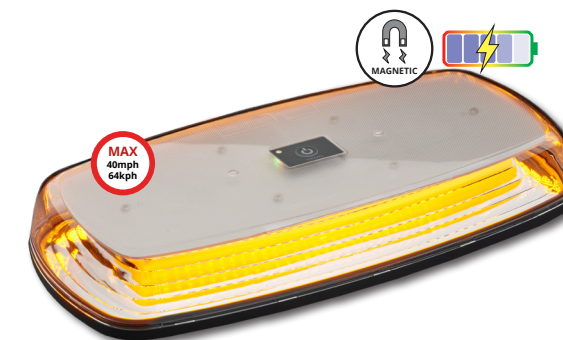

## LAPS155BAT

R10 APPROVED  
2 YEAR WARRANTY

- Manufactured with 5 x 3W LEDs
- 1000 effective Lumen
- IP44 ingress protection
- Rechargeable battery with 5 hour discharge time
- Dimensions: 132 (L) x 118 (W) x 275mm (H)
- Supplied with in-car and mains power adaptors

